



MOBILE HOME

PAMPHLET

Permits Issued 9:00 a.m. - 4:00 p.m.
Mon. – Fri (828-894-3739)

NO PERMITS WILL BE ISSUED FOR ANY PRE-1976 MOBILE HOMES

BRING THE FOLLOWING INFORMATION WITH YOU TO THE BUILDING INSPECTION OFFICE WHEN YOU ARE READY FOR YOUR MOBILE HOME PERMIT.

1. SEPTIC TANK & WELL APPROVAL

Your approval for septic system & well must be obtained from the Environmental Health Specialist at the Health Dept. (828-894-8004)

2. MOBILE HOME PERMIT AUTHORIZATION

Obtain this authorization from the Polk County Tax Office in the Womack Justice & Administration Building. (Tel. 828-894-8954)

3. ZONING/Floodplain/Watershed

If your mobile home will be placed within the zoning limits of an incorporated town (Columbus, Saluda, or Tryon), you must obtain a Zoning Permit from that town. For all locations outside of the zoned limits, see the County Planning Director (Tel. 828-894-2732) for information on Zoning. *Depending on the property location where your mobile home will be placed, you may also need approval from the Planning Director for Flood Zone or Watershed Protection.*

4. 911 ADDRESS
See the Building Inspection Dept. to apply for your new address. (828-894-2732)

5. CONTRACTORS

The name and North Carolina State license number are required for both the Set-up Contractor*, the Electrical Contractor, and the Heating Contractor (if installing a Heat system).

***SET-UP CONTRACTOR**

Manufactured home set-up shall be performed by a NC State licensed set-up contractor or licensed dealer. An individual may set-up his or her own home provided they comply with the State of NC Regulations for Manufactured Homes.



Tape the permit in the window of the home so that it can be easily seen. Give the permit number to your electrical contractor. The electrician will be responsible for calling in the electrical work. You will be responsible for calling for an inspection on the other items. The home must be unlocked or someone home at the time of the inspection.

ITEMS TO BE INSPECTED

- Soil Bearing Test*
- Footings (when required)
- Drainage of Site
- Marriage of Joints (when applicable)
- Stabilizing system
- Anchoring
- Stairs (required at all doors)
- Water shutoff
- Sanitation connections
- All electrical work
- Skirting (when required)**

*Soil Bearing Test Information must be in the Building Inspections Office before a final inspection will be scheduled.

**No skirting shall be installed before final inspection. When skirting is required, the skirting must be installed and inspected within 120 days from date of final inspection.

INSTALLATION MANUAL

Manufactures of HUD-labeled homes are required by the federal regulations to provide each home with "Consumer" and "Installation" manuals. The "Consumer" manual generally describes features and required maintenance of the home. The "Installation" manual is required to describe one (1) foundation and anchorage system and instructions for site construction and connections. In the absence of these instructions, set-up shall be done in accordance with the State of North Carolina Regulations for Manufactured/Mobile Homes.

DRAINAGE SITE

Each site shall have a finished grade that will provide for drainage away from the home.



Notify the proper utility service as soon as your site is chosen!!

- Duke Power - 894-5938
- Rutherford Electric - 1-800-521-0920
- Broad River Electric - 864-489-5737



You will be contacted with your new address after it has been assigned.

STAIRWAYS/HANDRAILS/GUARDS

Each manufactured home shall have a minimum of two remote exterior exit doors. Where the exit doors from a home are not substantially level with the ground, stairs or ramps shall be constructed or installed by the selling party, unless specifically contracted otherwise by the homeowner.

Steps and Stairway:

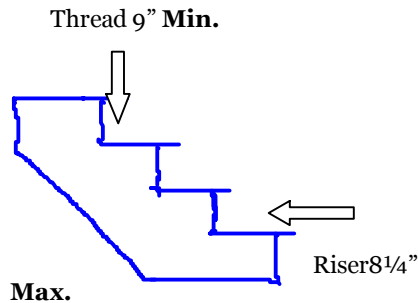

Width. Stairways shall not be less than 36 inches in clear width. The minimum width at and below the handrail height shall not be less than 32 inches where a handrail is installed on one side and 28 inches where handrails are provided on both sides.

Profile. The radius of curvature at the leading edge of the tread shall be no greater than 9/16 inch. A nosing not less than 3/4 inch but not more than 1-1/4 inches shall be provided on stairways with solid risers. Risers shall be vertical or sloped from the underside of the leading edge of the tread above at an angle not more than 30 degrees from the vertical. Exception: A nosing is not required where the tread depth is a minimum of 11 inches.

Treads and Risers. Maximum riser height shall be 8 1/4 inches and minimum tread depth of 9 inches, exclusive of nosing. The risers' height shall be measured vertically between leading edges of the adjacent treads. The tread depth shall be measured horizontally between the vertical planes of the foremost projection of adjacent treads and at a right angle to the tread's leading edge. The walking surface of treads and landings of a stairway shall be sloped no steeper than one unit vertical in 48 units horizontal (2% slope). The greatest riser height within any flight of stairs shall not exceed the smallest by more than 3/8 inch. The height from the top tread or top of a landing (when a landing is present) to the door threshold shall not exceed 8-1/4 inches. Where the bottom riser of an exterior stair adjoins an exterior walk, porch, driveway, patio, garage floor, or finish grade, the height of the riser may be less than the height of the adjacent risers.

Handrails. Handrails having minimum and maximum heights of 30 inches to 38 inches, respectively, measured vertically from the nosing of the treads, shall be installed on all open sides of stairways of four or more risers or when the elevation of the top of the uppermost riser is more than 30" above floor or grade below that leads to a door, platform, porch, terrace, or entrance landing. All required handrails shall be continuous the full length of the stairs. Ends shall be returned or shall terminate in newel posts of safety terminals.

Guardrail and handrail. Porches, balconies or raised floor surfaces located more than 30 inches above the floor or grade below shall have guardrails not less than 36 inches in height. The *handgrip portion* of the handrails shall not be more than 3-1/2 inches in cross-sectional dimension, lid risers. Beveling of nosing shall not

exceed 1/2 inch or the shape shall provide an equivalent gripping surface and surface shall be smooth with no sharp corners.

Guardrails and handrails as required on open sides of stairways, raised floor areas, balconies and porches shall have intermediate rails or ornamental closures which do not allow passage of an object 6 inches or more in diameter. *Horizontal spacing* between the vertical members in required guardrails shall be a maximum of 4 inches at the nearest point between the members. *Exception: The triangular openings formed by the riser, tread and bottom rail of a guard at the open side of a stairway may be of such a size that a sphere 6 inches cannot pass through.* All lumber subject to the weather must be of approved durable or treated wood.

Ramps: Ramps shall be at least three feet (3') wide. The slope of the ramps shall not exceed one foot in twelve feet.

Landings: A minimum 3' x 3' landing shall be required at the top of all exterior stairs where any egress door (not screen or storm door) swings outward over the stairs. Landings which are 36 square feet or less in area may be constructed according to the provisions of this Code. All such landings, whether at the top or bottom of the stairs, which are greater than 36 square feet in area are considered to be "decks" and shall be constructed in accordance with NC State Residential Code (current edition).

AUXILIARY STRUCTURES

All auxiliary structures (such as porches, decks, awnings, stairs, etc.),

unless provided or approved by the manufacturer shall be entirely self-supporting, unless designed and approved by a Professional Engineer or Architect. All such structures shall be constructed in accordance with the North Carolina State Building Code. Design all attached buildings and structures to support all of their own live and dead loads, unless otherwise approved by manufacturer and Professional Engineer or Architect. Provide fire separation as required for occupancy by State Code.

EXPIRATION OF PERMIT

A mobile home permit shall expire six (6) months from the issue date.



**HOT LINE FOR
RESIDENTS OF
MANUFACTURED
HOMES**

The toll-free number is 1-800-587-2716.

Disclaimer: This information has been assembled from the State of NC Regulations for Manufactured/Mobile Homes and other various sources. Although every attempt has been made to ensure accuracy, information to be utilized should be verified from the authority having jurisdiction over the job.